

PROGRESSIVE CAVITY PUMPS

2018 | 1

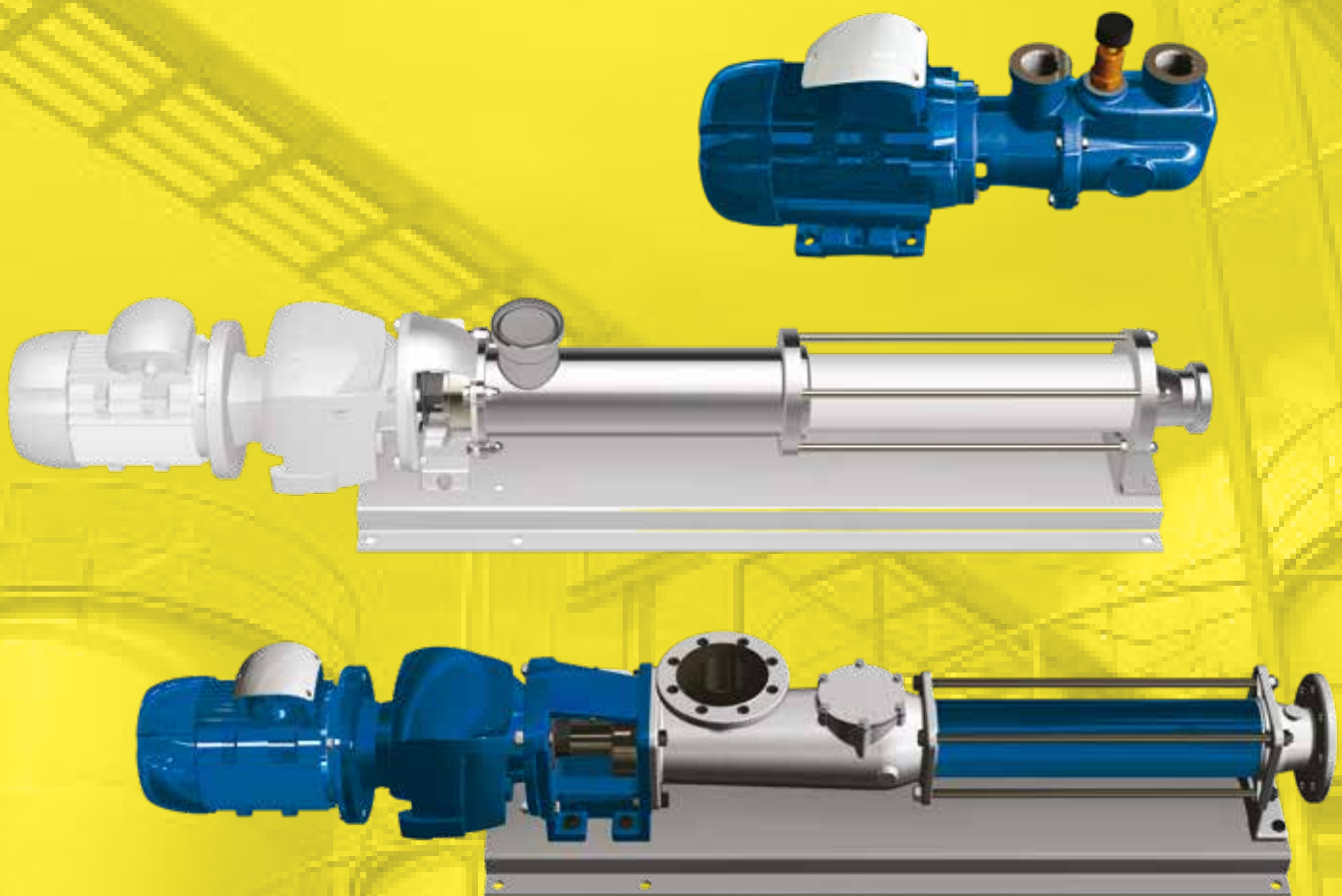

All about your flow

Tapflo is a leading pump manufacturer with the ambition to provide a wide range of premium products for various industrial applications. We focus on delivering the best fluid processing solutions and support on all stages of the process, worldwide.



About Tapflo

Tapflo is an independent, Swedish, family owned manufacturer and global supplier of air operated diaphragm pumps, centrifugal pumps and other industrial process equipment. The company was founded in Kungälv, Sweden in 1980 and has since then been working with design and manufacture of thermoplastic, metal and sanitary series diaphragm pumps, as well as the complete range of centrifugal pumps and industrial equipment. After years of dynamic development, the company evolved into Tapflo Group with worldwide operations. Tapflo Group is represented by owned companies and independent distributors all over the world on 6 continents.

Quality certified

At Tapflo, we believe that quality is one of the highest values, both for our customers as well as our employees. As a result, we comply with various globally recognised certification and quality control institutions. Many of our products comply with EC ATEX directives for equipment intended for used in explosive and hazardous environments.

The aseptic series is EHEDG certified (European Hygienic Engineering & Design Group) and the pharmaceutical series has USP VI and EC 1935/2004 approval.

All of our products are clearly CE marked and followed by our comprehensive instruction manuals. Tapflo manufacturing process is certified according to ISO 9001:2015.



Our values

■ Long term engagement is our core

Our aim is to continuously provide premium products according to the evolving needs of our customers. That is why we see each customer relationship as a long term commitment.

■ Local means on your terms

Tapflo is your global partner providing local support. No matter where your plant is located, you can expect us to support you locally.

■ Flexibility the foundation of good service

We are prepared to deal with reality, knowing that in practice this means answering questions, offering solutions and supplying spare parts with a minimal loss of time.

■ Customising to bring the product to the needs

Our intention is always to help our clients find the most cost effective solutions to increase their company's efficiency.

If this means changing the design of the pump, we see it as a challenge - not a problem.

■ To produce is to develop

Being actively involved in the manufacturing of a product, it is almost impossible not to discover ways to improve it.

This allows us to frequently offer solutions that are even more sustainable and efficient.

Typical applications



Waste and sludge treatment

pumping sludge storage; treated sludge



Food Industry

paste consisting of solid fragments of pits, skins and pulp; the olive paste; oil must; oil obtained from the separation stage (oil from the residual water); filtered oil; pumping crushed and destemmed must; pomace; wine; convey wine; filtered wine



Biogas Industry

pumping liquid livestock manure; injecting liquid manure; zootechnical waste; partially fermented biomass; digestate



Papermaking Industry

transfer cellulose pulp; pumping pulp obtained; paper pulp obtained; dyes, fillers and fixatives; waste waters obtained

R & RF Series - Wobble pumps

The ideal solution for those seeking a highly compact and versatile product.

They can be used in a variety of industrial applications due to their ability to pump products which are viscous, which have solids in the fluid or which are mildly abrasive.

Perfect for those seeking a highly efficient, economical product, these offer an unparalleled cost/benefit advantage.

Even at high rpms, the pump operates without pulsation and there is virtually no centrifugal effect. They are also suitable for use within the food industry, as there are no dead zones within the pump.



Fast facts

- Flow rate: up to 6 m³/h
- Pressure: 4 bar (6 bar for intermittent use)
- Temperature: from 0 °C up to 80 °C

Typical application

- » Food Industry
- » Oil Industry
- » Waste and sludge Industry

Features & Benefits

- ✓ Easy and economical to maintain, due to the very small number of component parts.
- ✓ Very low pulsation and tensional stress.
- ✓ Successfully combines incomparable.
- ✓ Technical features with very competitive costs.
- ✓ Easy to install, due to their compact size, their simplicity of operation and their operational flexibility, and the various fittings available.
- ✓ Solidly constructed housings in cast iron, bronze and stainless steel (AISI Type 304 and AISI Type 316), manufactured using lost wax casting technology.
- ✓ Allow excellent priming abilities - up to 4m

R & RF Series - design

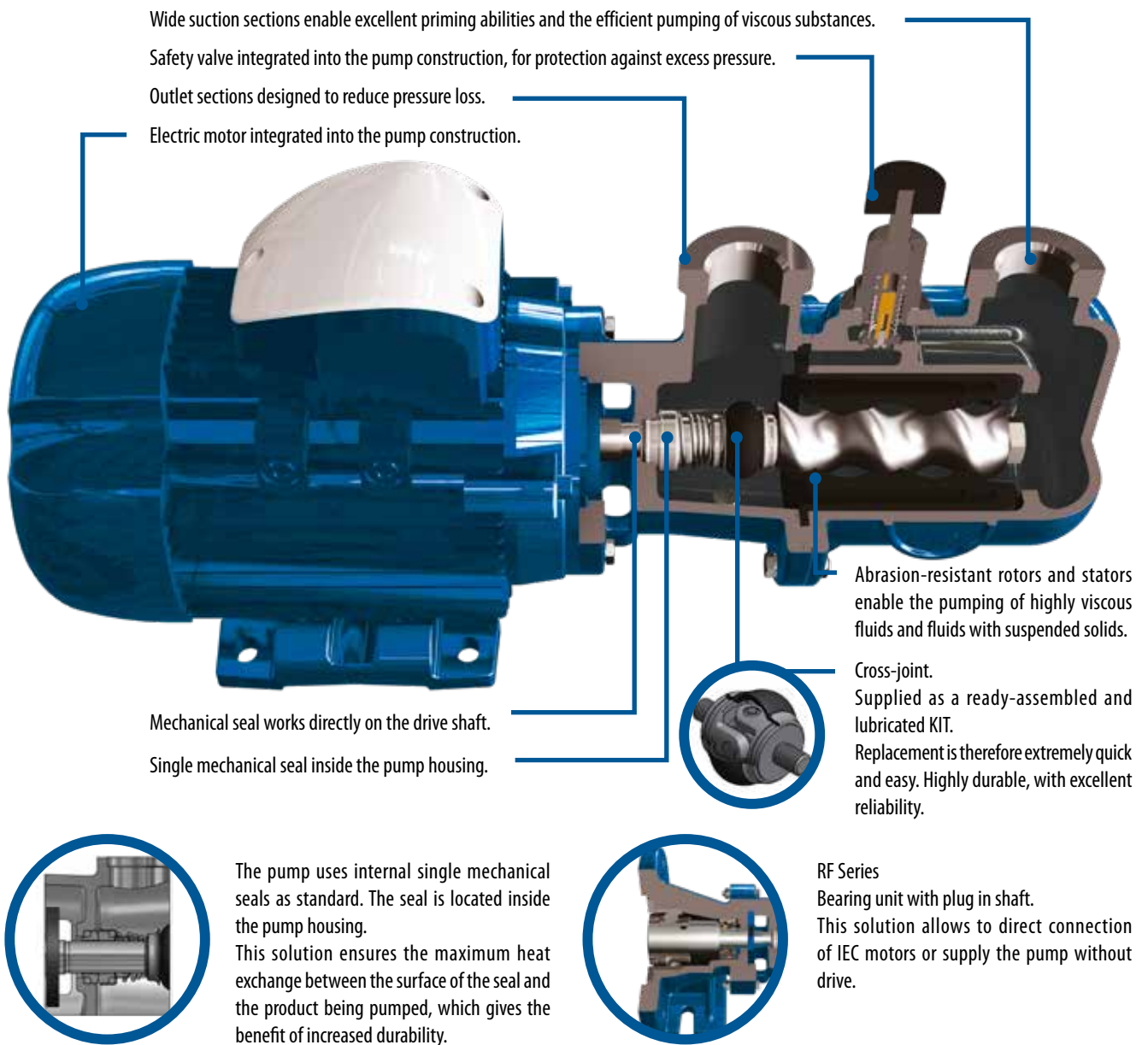

Materials

Casing Material	GG25, CF8 (AISI Type 304), CF8M (AISI Type 316), Bronze
Shaft seal material	AISI Type 316
Rotor materials	AISI Type 304, AISI Type 316; Coatings: Thick hard chrome coating
Stator materials	NBR, food-grade NBR, white food-grade NBR; EPDM, food-grade EPDM, white food-grade EPDM; FPM
Connections	Threaded GAS BSP connections; DIN 11851
Seal systems	Single mechanical seal
Protection devices	Flow switch; Pressure switch
Control devices	Electrical panel; Electrical panel with inverter; Motor with integrated inverter
Options and fittings	By-pass integrated into the pump construction
Certification	CE

R Series flow rates and pressures

Size	Poles	Capacity* [m ³ /h]	Max speed of rotation [rpm]	Max pressure [bar]	Power [kW]
R 24	4	0,55	1400	4	0,25
	6	0,35	900	4	0,18
R 28	4	0,33	1400	4	0,25
	6	0,21	900	4	0,18
R 45	4	2,70	1400	4	0,55
	6	1,70	900	4	0,55
	8	1,30	700	4	0,25
R 49	4	1,05	1400	4	0,55
	6	0,67	900	4	0,55
	8	0,52	700	4	0,25
R 64	4	3,50	1400	4	1,10
	6	2,25	900	4	0,75
	8	1,75	700	4	0,55
R 68	4	3,00	1400	4	1,10
	6	1,90	900	4	0,75
	8	1,50	700	4	0,55
R 84	4	5,90	1400	4	2,20
	6	3,80	900	4	1,50
	8	2,90	700	4	0,75
R 88	4	4,20	1400	4	2,20
	6	2,70	900	4	1,50
	8	2,10	700	4	0,75

*capacity are based on water 20 °C at pressure 2 bar.

Other types of wobble pumps

RL Series

Is an extremely compact product thanks to the integrated pump-electric motor construction. The patented pin joint of the Diamond series ensures high reliability. The support between the body pump and drive unit has been eliminated which makes the pump more compact and easier to maintain.



RJL Series

Is based on the same technology as the RL series. The difference lies in its use of a bearing unit and free bare shaft.

The RJL series can be connected to the drive with a flexible coupling. The ideal solution for the supply of a bare shaft pump. The bearings ensure the highest reliability in all operating conditions.

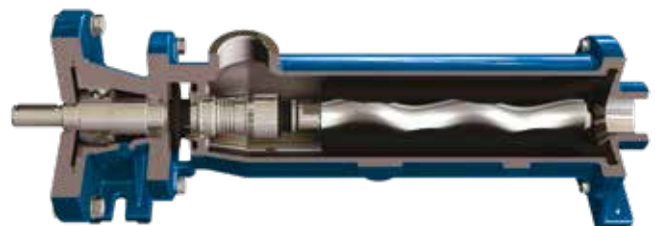

RFL Series

Is based on the same technology as the RL series. The difference lies in its use of a bearing unit with plug-in shaft.

The RFL series can be flanged directly to the drive. This is the ideal solution for the supply of a pump without a drive system, while maintaining compactness and easy installation. The bearings ensure the highest reliability in all operating conditions.



Changes reserved without notice

DN Series - Diamond series

The best solution for the industrial sector in pumping a vast range of fluids. They are synonymous with strength, reliability, performance and application flexibility.

Designed according to the most demanding standards, they comply with the requirements of standard API 676.

Suitable for pumping viscous and non-viscous products, with or without solids of any nature, they are an ideal solution for those seeking a standard product with advanced technology with unbeatable cost benefits in the current single screw pumps market.

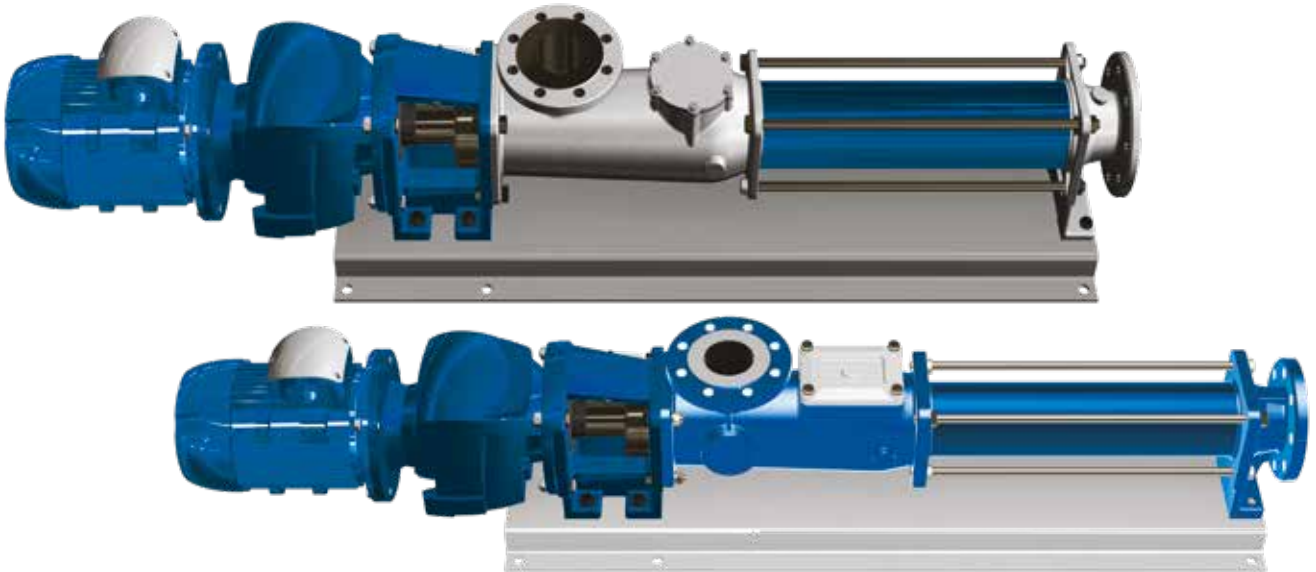

■ Fast facts

Flow rate: up to 480 m³/h
Pressure: up to 48 bar
Temperature: from 0 °C up to 150 °C

■ Typical application

- » Water treatment
- » Chemical Industry
- » Waste and sludge Industry
- » Paper Industry
- » Marine Industry
- » Agriculture

■ Features & Benefits

- ✓ Extremely cheap and compact, considerably reducing installation costs and simplifying maintenance.
- ✓ Easy to install due to compactness, simplicity of operation and operational flexibility thanks to the various features included.
- ✓ Allow excellent self-priming (up to 7m).
- ✓ Tensional stress and pulsating flow are very low.
- ✓ Its elements combined technical success without comparison at very competitive costs.

DN Series - design

Rotating parts in stainless steel as standard also for cast iron pumps.

Extremely strong housings, suitable to support drive loads.

Ample suction sections enable excellent driving capacity and makes pumping of viscous substances efficient.

Output sections suitable for reduced load loss.

Rotors and stators resistant to abrasion.

The Diamond series is based on the concept of modularity in every characteristic: hydraulic parts, casing, seals, base plates, housing, drive shafts. Each part can be manufactured in a series of variants without changing the structure of the machine, while keeping the main spare parts standard.

Inspection doors as standard on the entire range for efficient cleaning of the casings

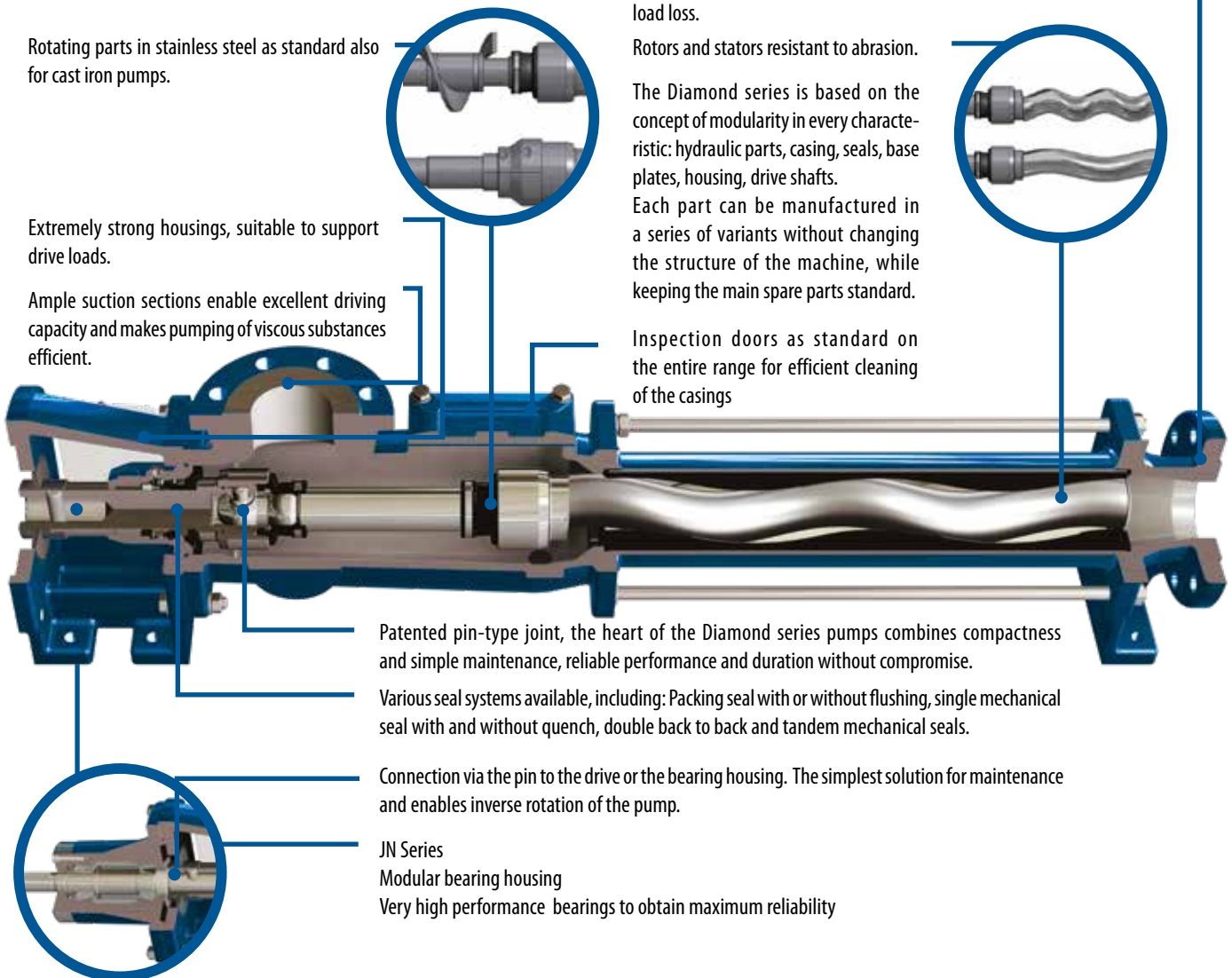

Patented pin-type joint, the heart of the Diamond series pumps combines compactness and simple maintenance, reliable performance and duration without compromise.

Various seal systems available, including: Packing seal with or without flushing, single mechanical seal with and without quench, double back to back and tandem mechanical seals.

Connection via the pin to the drive or the bearing housing. The simplest solution for maintenance and enables inverse rotation of the pump.

JN Series
Modular bearing housing
Very high performance bearings to obtain maximum reliability

Materials

Casing Material	GG25, CF8 (AISI 304), CF8M (AISI 316), F55 (Super duplex); Coating: fluoropolymer ECTFE (Halar®)
Sealing shaft	AISI 420, AISI 304, AISI 316, F51(Duplex), F55 (Super Duplex); Coatings: Hardened Chrome plated HCP, Chrome oxide plasma (ceramic coating)
Rotor materials	Base materials: AISI 420, AISI 304, AISI 316, F51(Duplex), F55 (Super Duplex); Heat treatments: Hardening induction (only on AISI 420), Coatings: Hardened Chrome plated HCP, Chrome oxide plasma (ceramic coating), Tungsten carbide HVOF
Stator materials	Base materials: NBR, food grade NBR, white NBR food grade; EPDM, EPDM food grade, white EPDM food grade; FPM, FPM food grade HNBR, HNBR food grade; SYLICON; Buna-N (available on select models on request); HYPALON (available on select models on request) PTFE (available on select models on request)
Base plates	standard Base; API 676 Base
Connections	Flange UNI 2278 PN16 for pumps at 1 and 2 stage; Flange UNI 2284 or 6084 PN40 for inlet unions for pumps at 4 stages; Flange UNI 2285 PN64 for inlet unions for pumps at 8 stage; Threaded connection GAS BSP
Seal systems	Gland packing seal; Single mechanical seal; Back-to-back double mechanical seal; Tandem double mechanical seal; Single or double cartridge seals
Optional for transmission shaft	Protector joint; Transmission shaft with feed screw; Anti-settling impeller; Balanced hydraulic joint
Protection devices	Temperature probe for dry running protection (standard in the ATEX version); Flow switch; Pressure switch; Flanged overpressure valve; Hygienic overpressure valve
Control devices	Control panel; Control panel with inverter; Drive with integrated inverter
Equipment and optional	Stator heating jacket; Heating jacket for body pump; Stainless steel stator cover; Integrated Bypass in the pump construction
Certifications	CE; ATEX; API 676 third edition

DH Series - Hopper pumps

The open hopper pumps with hydraulic auger feed screw are ideal for handling high-consistency materials with a low degree of flowability and high solid content.

DH Series

Standard model equipped with rectangular hopper and an auger feed screw that moves the product to the hydraulic part. The length can be adapted to suit the application.

DHE Series

This model has a large eccentric hopper, with integrated trolley, ideal for the wine industry in conjunction with destemmers-crusher.

DHS and DHS - T Series

This model features a rectangular hopper and enlarged auger feed screw that moves the product to the hydraulic part. The length can be adapted to suit the application.

DHP Series

Model fitted with wide hopper, single bridge breaker shaft and auger feed screw that moves the product to the hydraulic part.

DHB Series

This model features a hopper with double bridge breaker shaft and an enlarged auger feed screw that moves the product to the hydraulic part. The length can be adapted to suit the application.

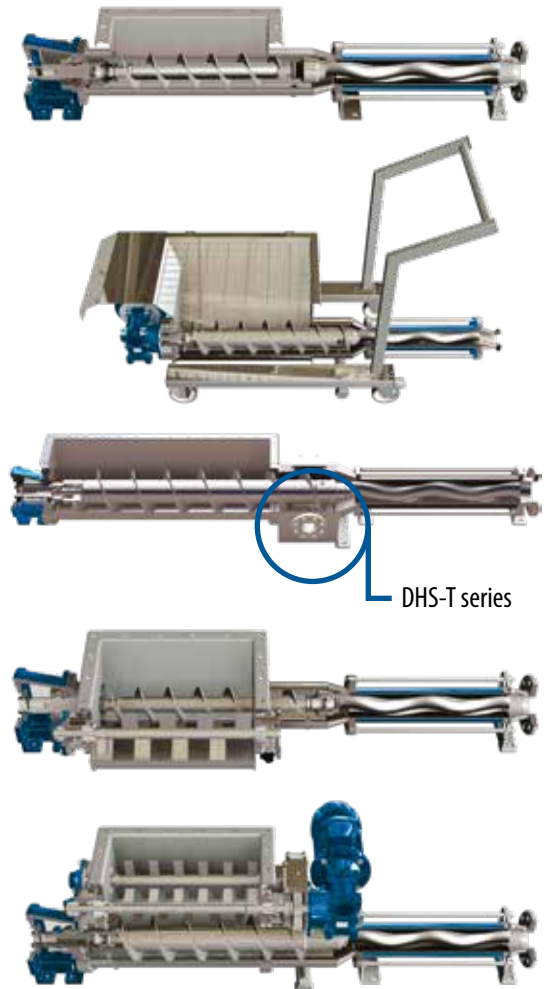

DHS-T series

DV Series - Vertical pumps

The Vertical series is the ideal solution for pumping viscous or non-viscous, abrasive and aggressive materials from tanks and wells.

There are two standard configurations: the short version and the long version.

The short version is compact robust and very easy to install.

Whereas the long version is ideal for installation in deep wells or tanks and feature a number of dedicated optimizations such as the removable inlet for easy maintenance of the rotor, stator and coupling.



DXO & DXC Series - Diamond Series

The DX hygienic pump series is state of the art for the food, pharmaceutical, chemical and cosmetic industries.

The complete sanitary design, in compliance with standards EHEDG and 3A, ensures maximum sanitisation.

These pumps are top rated for "Clean In Place" and "Sterilizing In Place". The geometry of the pumps is designed specifically to allow drainage and avoid dead zones. Each component is manufactured with the highest level of finish and utmost cleanliness.

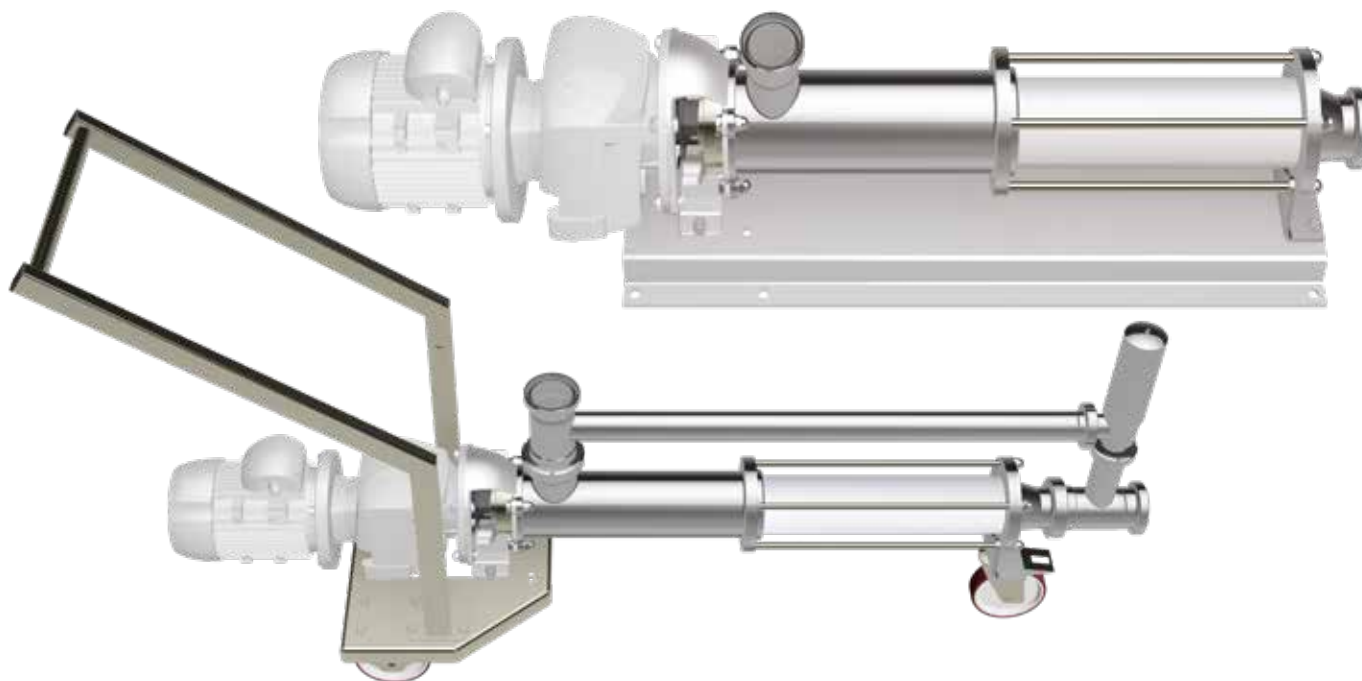

Fast facts

Flow rate: up to 110 m³/h
Pressure: up to 48 bar
Temperature: from 0 °C up to 150 °C

Typical application

- » Wine Industry
- » Milk & dairy
- » Sugar Production
- » Beverages & Breweries
- » Distilleries
- » Tomato Production

Features & Benefits

- ✓ This solution is extremely cost effective and compact, considerably reducing installation costs and simplifying maintenance.
- ✓ Easy to install due to compactness, simplicity of operation and operational flexibility thanks to the various features included.
- ✓ Allow excellent self-priming (up to 7m).
- ✓ Tensional stress and pulsating flow very low.
- ✓ Its elements combined technical success without comparison at very competitive costs.

DXO Series

Hygienic pump with open joint.

It is the solution with the best sanitisation characteristics thanks to the design of the casing and the rotating parts completely free of dead zones and stagnation.

Lubrication of the joint is guaranteed by the product thanks to its open design, therefore it is suitable for non-abrasive fluids. Performance improves considerably when pumping lubricant products.

Open joint with superior sanitization characteristics. This joint is particularly strong thanks to the dimensions designed to ensure its performance despite the lack of lubrication with specific products.

The biggest benefit counts in its fast maintenance, for assembly and dismantling there is no need for any tool or product for sealing or lubricant.

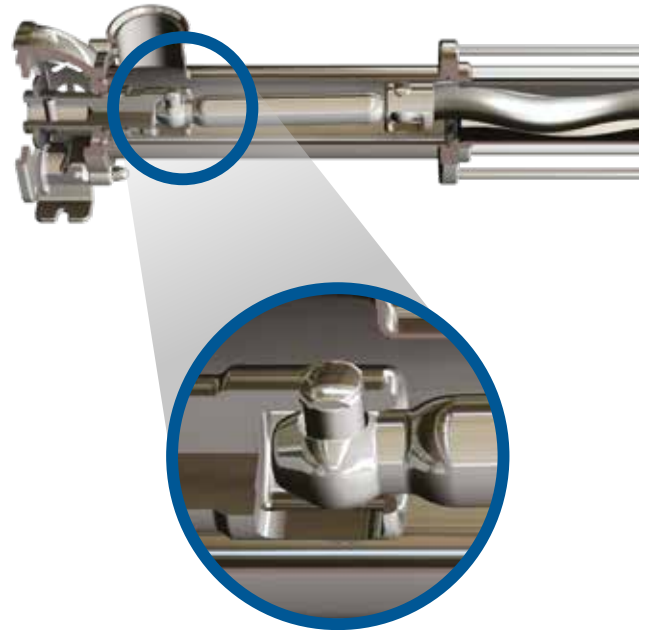

DXC Series

Hygienic pump with pin, standard to the DN series.

This solution combines excellent sanitisation characteristics thanks to the design and casing completely free of dead zones and stagnation, together with the performance of the pin-type joint patented in the Diamond series.

Lubrication of the pin is independent of the pumped product, therefore it is also suitable for abrasive fluids.

The pin-type joint, the actual heart of the single screw pump, is the best solution of its type on the market. It offers greater duration, reliability and maintenance costs, managing to combine extreme compactness with unrivalled strength.

Its particular manufacturing enables the sub-division of axial loads and torque in different elements, making it one of a kind. To resist high pressure in the pump casing up to 12 bar, the pin can be hydraulically balanced.

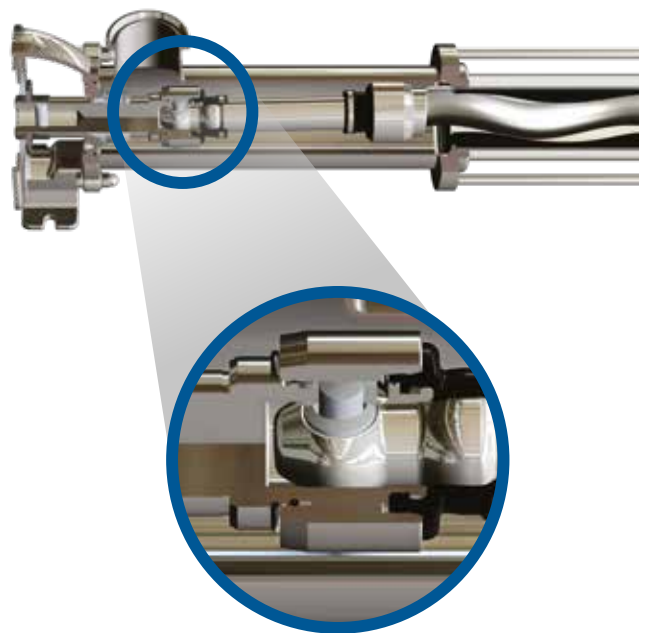

DX Series - design

The stator funnel is manufactured with rounded geometry to avoid deposits contaminating the product.

Rotating parts in stainless steel. Each part has a highly precious finish to improve sanitisation.

Lantern manufactured as standard in stainless steel. Extremely strong and designed for easy cleaning.

Ample suction sections enable excellent drying capacity and makes pumping of viscous substances efficient.

Output sections suitable for reduced load loss. Eccentric cone to avoid dead zones or stagnation points.

Rotors and stators resistant to abrasion.

The Diamond series is based on the concept of modularity in every characteristic: hydraulic parts, casing, seals, base plates, housing, drive shafts. Each part can be manufactured in a series of variants without changing the structure of the machine, while keeping the main spare parts standard.

CIP connection built into pump body. This option enables insertion of washing fluid in the pump body to clean hygienic pumps in the best way possible. Manufactured tangential to the body, it avoids stagnation and enables efficient drainage of the fluids.

Patented pin-type joint, the heart of the Diamond series pumps. Combines compactness, simple maintenance, performance, reliability and duration without compromise.

Various seal systems available, including: single mechanical seal with and without quench, internal and external single mechanical seal, double back to back and tandem mechanical seals.

JX Series
Modular bearing housing
Very high performance bearings to obtain maximum reliability Connection via the pin to the drive or the bearing unit. The simplest solution for maintenance and enables inverse rotation of the pump.

Materials

Casing Material	Base materials: AISI 304, AISI 316
Rotor materials	Base materials: AISI 420, AISI 304, AISI 316, F51(Duplex), F55 (Super Duplex); Heat treatments: Hardening induction (only on AISI 420); Coatings: Chrome oxide plasma (ceramic coating); Tungsten carbide HVOF
Stator materials	Base materials: NBR, white NBR food grade; EPDM, white EPDM food grade; FPM, FPM food grade; HNBR, HNBR food grade; SYLICON; Buna-N (on select models on request); HYPALON (on select models on request); PTFE (on select models on request)
Connections	DIN 11851; DIN 11864-1 / DIN 11864-2 / DIN 11864-3; Clamp (ISO 2852, ASME-3A, 32676); RJT; SMS 1145; Garolla; Macon
Seal systems	Single internal mechanical seal; Single external mechanical seal; Single mechanical seal; Back-to-back double mechanical seal; Tandem double mechanical seal; Single or double cartridge seals
Optional for coupling rod	Joint Protector; Coupling rod with feed screw; Antisettling impeller; Balanced hydraulic joint (only on DXC series)
Protection devices	Temperature probe for dry running protection (standard in the ATEX version); Flow switch; Pressure switch; Flanged overpressure valve; Hygienic overpressure valve
Control devices	Control panel; Control panel with inverter; Drive with integrated inverter
Equipment and optional	Stator heating jacket; Heating jacket for body pump; Stainless steel stator cover; Grinder; CIP Connection integrated on the body pump; Integrated Bypass in the pump construction; Quench Pot flushing; Lantern in stainless steel; Hermetic Lantern; Carter to protect the motorization
Certifications	CE; ATEX

Diamond Series (DN, DH, DV, DX, DXO, DXC) flow rates and pressures

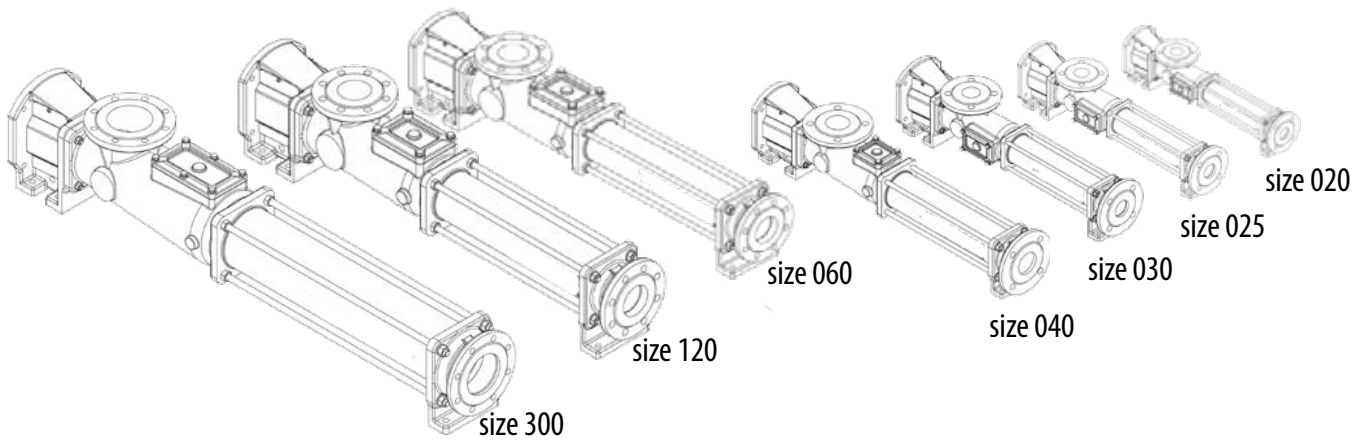

Size	Model	Capacity* [m ³ /h]	Max speed of rotation [rpm]	Max pressure [bar]
D 020	1L1	4,90	1400	6
	05K2	2,50	1400	12
	025K4	0,70	800	24
D 025	2L1	6,90	1000	6
	1K2	9,40	1000	12
	1K4	1,50	800	24
	25K8	0,50	600	48
D 030	4L1	11,00	800	6
	2K2	5,60	800	12
	1K4	2,20	600	24
	05K8	1,00	500	48
D 040	10L1	16,50	600	6
	4K2	8,50	600	12
	2K4	3,70	500	24
	1K8	1,50	400	48
	16L1	23,50	600	4
	8K2	12,00	600	8
D 060	20L1	28,00	500	6
	10K2	14,00	500	12
	4K4	5,70	400	24
	2K8	2,60	350	48
	30L1	33,00	500	4
	16K2	16,50	500	8
D 120	40L1	43,00	400	6
	20K2	20,00	400	12
	10K4	10,00	350	24
	4K8	5,00	350	48
	60L1	63,50	400	4
	30K2	32,00	400	8
D 300	80L1	76,00	350	6
	40K2	38,00	350	12
	20K4	15,40	300	24
	10K8	8,50	300	48
	120L1	110,00	350	4
	60K2	55,00	350	8

*capacity are based on water 20 °C at pressure 2 bar.

Changes reserved without notice

Applications



DHE pump
Transfer of the fermented pomace



DHS pump
Used after filter press for the recycling of the dried sludge.



DN pump
Used for transferring of pulp/olive paste.



R pump with wobble stator
For pumping vegetables waters.



DHS-T and DN pump
Transferring biomass to the digester with phase liquid injection.



DV pump
The machine is immersed directly into the product therefore there is no need for suction pipes which reduces the footprint to the minimum.

Product range

Diaphragm pumps & accessories



PE & PTFE pumps



Metal pumps



Pharmaceutical pumps



Sanitary pumps



TC Intelligent pumps



Powder pumps



TF Filter press pumps



EHEDG aseptic pumps



Active pulsation dampeners



Systems & accessories



Trolleys



Centrifugal pumps, filter units & accessories



CTI & CTH centrifugal pumps



CTP plastic centrifugal pumps



CTM magdrive centrifugal pumps



CTV vertical centrifugal pumps



CTS self-priming centrifugal pumps



Trolleys



FT Filter units

Sweden

Filaregatan 4 | S-442 34 Kungälv

Tel: +46 303 63390

Fax: +46 303 19916

E-mail addresses:

Commercial questions: sales@tapflo.com

Orders: order@tapflo.com

Tech support: support@tapflo.com

Tapflo products and services are available in 75 countries on 6 continents.

Tapflo is represented worldwide by own Tapflo Group Companies and carefully selected distributors assuring highest Tapflo service quality for our customers' convenience.

AUSTRALIA | AUSTRIA | AZERBAIJAN | BAHRAIN | BELARUS | BELGIUM | BOSNIA | BRAZIL | BULGARIA | CANADA | CHILE | CHINA | COLOMBIA | CROATIA | CZECH REPUBLIC | DENMARK | ECUADOR | EGYPT | ESTONIA | FINLAND | FRANCE | GREECE | GEORGIA | GERMANY | HONG-KONG | HUNGARY | ICELAND | INDIA | INDONESIA | IRAN | IRELAND | ISRAEL | ITALY | JAPAN | JORDAN | KAZAKHSTAN | KUWAIT | LATVIA | LIBYA | LITHUANIA | MACEDONIA | MALAYSIA | MEXICO | MONTENEGRO | MOROCCO | THE NETHERLANDS | NEW ZEALAND | NORWAY | POLAND | PORTUGAL | PHILIPPINES | QATAR | ROMANIA | RUSSIA | SAUDI ARABIA | SERBIA | SINGAPORE | SLOVAKIA | SLOVENIA | SOUTH AFRICA | SOUTH KOREA | SPAIN | SUDAN | SWEDEN | SWITZERLAND | SYRIA | TAIWAN | THAILAND | TURKEY | UKRAINE | UNITED ARAB EMIRATES | UNITED KINGDOM | USA | UZBEKISTAN | VIETNAM

Tapflo Group Companies

Austria

Tapflo Austria
Tel: +43 732 27292910
sales@tapflo.at

Azerbaijan

Tapflo Makina Ltd
Tel: +90 216 467 33 11
sales@tapflo.com.tr

Baltic States

Tapflo Latvia
Tel: +371 67472205
sales@tapflo.lv

Belarus

Tapflo Belarus
Tel: +375 17 3934609
sales@tapflo.by

Bulgaria

Tapflo EOOD
Tel: +359 (0)2 974 18 54
office@tapflo.bg

Canada

Tapflo Canada
Tel: +1 514 813 5754
canada@tapflo.com

Croatia

Tapflo GmbH
Tel: +385 91 4884 666
sales@tapflo.hr

Czech Republic

Tapflo s.r.o.
Tel: +420 513 033 924
tapflo@tapflo.cz

China

Tapflo (Wuxi)
Tel: +86 510 8241 7072
sales@tapflo.cn

Denmark

Tapflo Danmark
Tel: +45 36 454600
info@tapflo.dk

France

Tapflo France
Tel: +33 1 34 78 82 40
info@tapflo.fr

Georgia

TOB Tapflo
Tel: +380 44 222 68 44
sales@tapflo.com.ua

India

Tapflo Fluid Handling India Pvt Ltd
Tel: +91 20 65000215
ac@tapflo.in

Ireland

Tapflo Ireland Ltd
Tel: +353 1 2011911
info@tapflo.ie

Italy

Tapflo Italia
Tel: +39 0362 306528
info@tapfloitalia.com

Japan

Tapflo Japan K.K.
Tel: +81-3-6240-3510
tapflojp@tapflo.co.jp

Kazakhstan

Tapflo Kazakhstan
Tel: +7 727 3278347
sales@tapflo.kz

Poland

Tapflo Sp. z o.o.
Tel: +48 58 530 42 12
info@tapflo.pl

Romania

S.C. Tapflo Rom. S.r.l.
Tel: +40 21 3451255
sales@tapflo.ro

Russia

Tapflo Company
Tel: +7 495 232 18 28
sales@tapflo.com.ru

Serbia

Tapflo d.o.o.
Tel: +381 21 44 58 08
sales@tapflo.rs

Slovakia

Tapflo s.r.o.
+421 911 137 883
tapflo@tapflo.sk

Slovenia

Tapflo GmbH
Tel: +386 68 613 474
sales@tapflo.hr

Spain

Tapflo Iberica
Tel: +34 91 8093182
avives@tapfloiberica.es

South Africa

Tapflo (Pty) Ltd
Tel: +27 31 701 5255
sales@tapflo.co.za

Turkey

Tapflo Makina Ltd
Tel: +90 216 467 33 11
sales@tapflo.com.tr

Ukraine

TOB Tapflo
Tel: +380 44 222 68 44
sales@tapflo.com.ua

Uzbekistan

Tapflo Uzbekistan
Tel: +998 712370940
sales@tapflo.uz

United Kingdom

Tapflo (UK) Ltd
Tel: +44 2380 252325
sales@tapflo pumps.co.uk